

BASIKBench

SELECTION AND ORDERING GUIDE



CUSTOM PRODUCTS & SERVICES

6286 Claude Way E, Inver Grove Heights, MN 55076-4435

PH: 888-444-1202 (Toll Free) or 651-452-0113 Fax: 651-452-2264

E-mail: Info@custom-products.com

Website: www.custom-products.com



K E W A U N E E

KEWAUNEE SCIENTIFIC CORPORATION

Serving the Technical Workplace since 1906.

Kewaunee offers a complete line of products to make your technical work environment more efficient and productive. Our "systems approach" to technical environment planning provides you with the expertise of our workstation professionals who draw on more than 80 years of experience to design optimum and effective technical workplaces.

TABLE OF CONTENTS

| | |
|--|----|
| Product Vocabulary | 2 |
| How to Select, Specify and Order | 3 |
| Basic Workstations. | 4 |
| Workstation Components | 5 |
| Shelving | 6 |
| Backsplashes | 7 |
| Storage | 8 |
| Mobile Pedestals | 9 |
| Lighting. | 10 |
| Bin Bars | 11 |
| Parts Bins | 11 |
| Tool Bars | 12 |
| Foot Rails | 12 |
| Accessories | 13 |
| ESD Options | 14 |
| General Ordering Information | 15 |

PRODUCT VOCABULARY

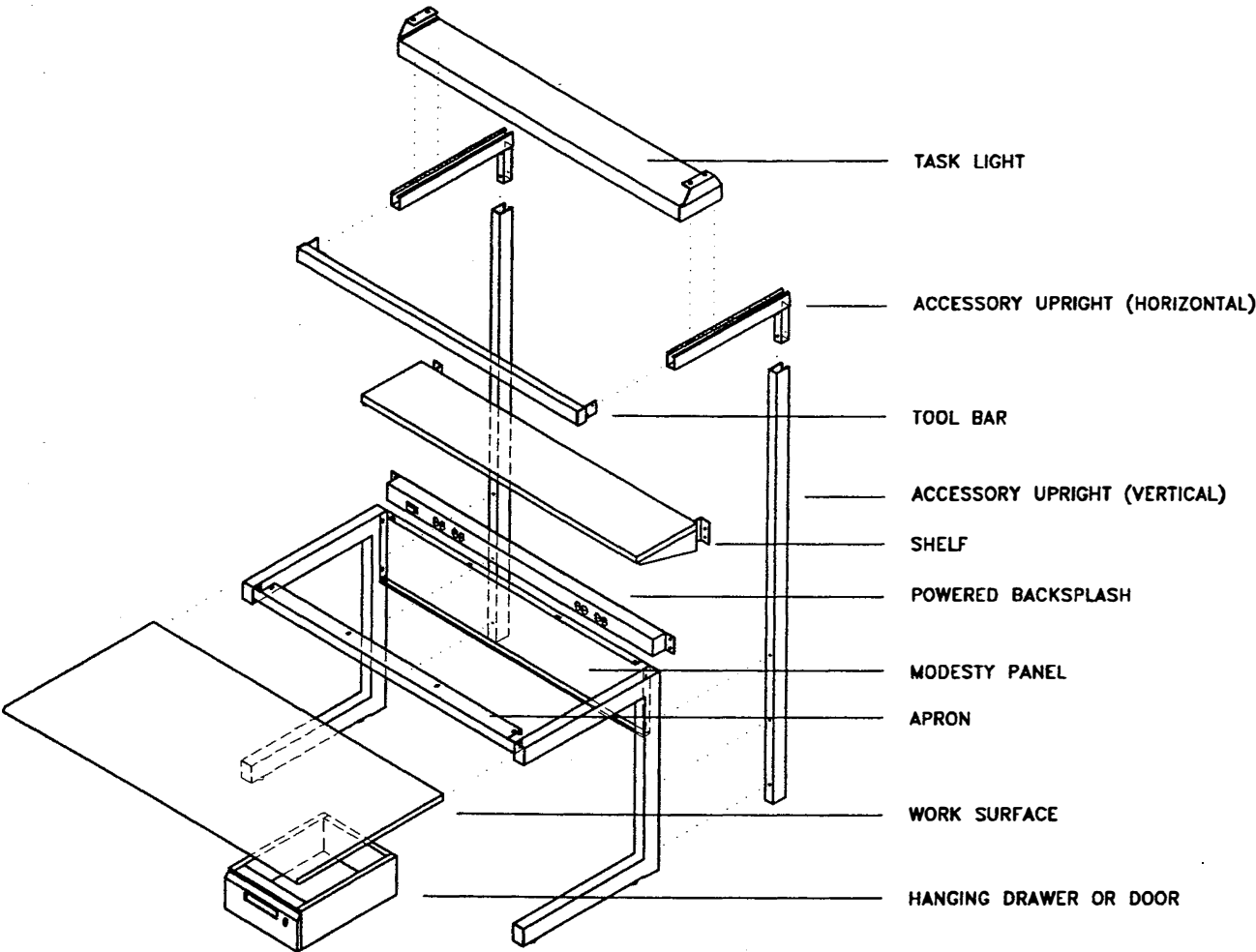

HOW TO SELECT, SPECIFY AND ORDER

Kewaunee recommends the specifications of the room layout be determined in advance of ordering the actual workstations. The end result is a well planned design that meets your requirements, saves money, and provides your personnel with an ergonomically designed, productive work area.

To Begin:

- (1) Measure the allocated space.
- (2) Determine personnel requirements.
- (3) Specify features important for operational requirements.

At any time, contact a local Kewaunee representative from a nationwide service network to provide you with assistance in determining your exact workstation requirements.

Ordering a Workstation:

1. Determine the desired height of the workstation: 36" Technical Height
30" Sit-Down Height
2. Choose the width of the workstation: 48", 60" or 72"
3. Select a worksurface type: Standard, ESD, or Maple
4. Specify the worksurface laminate color with a suffix to the product number:

Example; Product Number 447084

A - Almond Laminate
G - Gray Laminate

5. Specify the painted steel color by handwriting it on the purchase order.

Standard Paint Colors: Sand Tan, Flint Gray, Fashion Blue, White or Black
Customized paint colors are available upon requests. Consult your Kewaunee Representative.

6. Select workstation accessories (ESD options, lighting, shelving, storage...etc.).
7. Record the product number and quantity of each item on the quotation request/purchase order.

BASIC WORKSTATIONS

Basic Workstations include a front radius edge laminate workspace or a square edge maple workspace, front apron, modesty panel, and (2) lower legs.

ESD Workstations are supplied with a grounding kit and static dissipative (ESD) laminate.

Maple workspaces are constructed of 1 1/4" thick, cured maple hardwood and finished with a non-glare, clear lacquer coating.

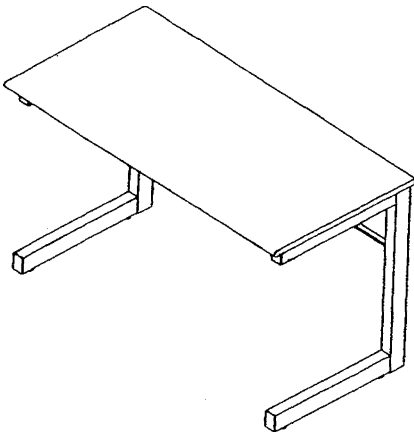

| (Technical) Leg Hgt. | Depth | Overall Width | Std. Laminate* | ESD Laminate* | Approx. Weight |
|-------------------------|-------|------------------|-------------------|------------------|-------------------|
| 36" | 29" | 48" | 447084_ | 447088_E | 130 |
| | | 60" | 447085_ | 447089_E | 160 |
| | | 72" | 447086_ | 447090_E | 190 |

| (Sit-Down) Leg Hgt. | Depth | Overall Width | Std. Laminate* | ESD Laminate* | Approx. Weight |
|------------------------|-------|------------------|-------------------|------------------|-------------------|
| 30" | 29" | 48" | 447074_ | 447078_E | 125 |
| | | 60" | 447075_ | 447079_E | 155 |
| | | 72" | 447076_ | 447080_E | 185 |

* Specify laminate color with a suffix to the product number:
Laminate Colors: **A** - Almond or **G** - Gray

| (Technical) Leg Hgt. | Depth | Overall Width | Maple Workspace | Approx. Weight |
|-------------------------|-------|------------------|--------------------|-------------------|
| 36" | 29" | 48" | 447084M | 135 |
| | | 60" | 447085M | 170 |
| | | 72" | 447086M | 205 |

| (Sit-Down) Leg Hgt. | Depth | Overall Width | Maple Workspace | Approx. Weight |
|------------------------|-------|------------------|--------------------|-------------------|
| 30" | 29" | 48" | 447074M | 130 |
| | | 60" | 447075M | 165 |
| | | 72" | 447076M | 200 |

ACCESSORY UPRIGHTS

Accessory Uprights are 76"H painted steel supports supplied in a set of (2). They can accommodate all mounted accessories including Lights, Tool Bars, Shelves, Bin Bars, and Backsplashes.

Accessory Uprights can also be supplied as individual parts when Task Lights or Tool Bars are not an immediate requirement. Vertical Uprights can accommodate Shelves, Bin Bars, and Upright Mounted Backsplashes. Horizontal Uprights can then be added when future requirements involve Task Lights or Tool Bars. Specify (1) set of Uprights below per workstation when ordering. Installation guide and mounting hardware are included.

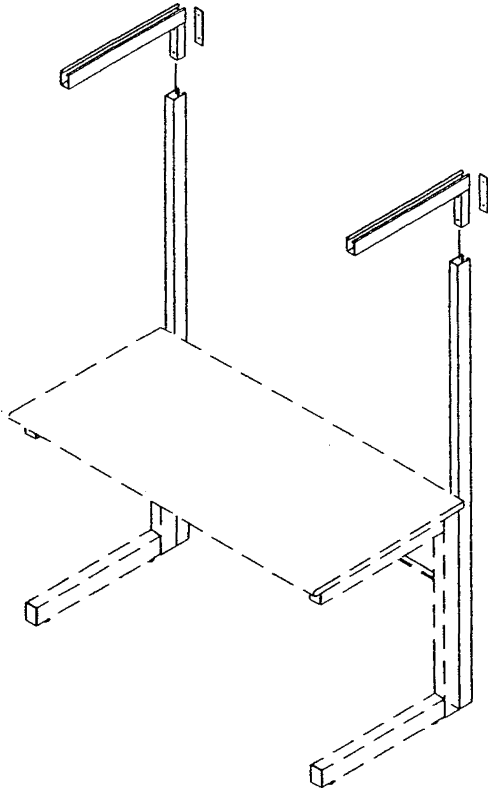

Accessory Uprights

| Description | Product Number | Approx. Weight |
|---------------------------------|----------------|----------------|
| Upright Assembly - Set of (2) | 447012 | 25 |
| Horizontal Upright - Set of (2) | 447011 | 7 |
| Vertical Upright - Set of (2) | 447013 | 18 |

SHELVING

Shelves are available in Painted Steel or Wire. Metal Shelves have a 1 5/8" lip that extends 1/2" above the shelf surface. In a level position, the shelf lip is located in the back and serves as a backstop. In an inclined position (invert brackets), the shelf lip is located in the front and serves as a gravity stop. The shelf lip can be used to hang parts bins. Mounting brackets are included.

Metal Shelves

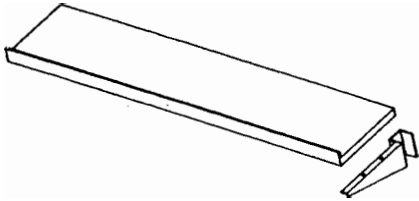

| Depth | Workstation Width | Product Number | Approx. Weight |
|-------|-------------------|----------------|----------------|
| 12" | 48" | 447062 | 23 |
| | 60" | 447063 | 25 |
| | 72" | 447064 | 27 |

Wire Shelves

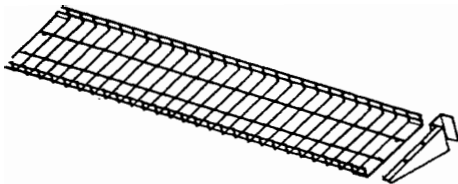

| Depth | Workstation Width | Product Number | Approx. Weight |
|-------|-------------------|----------------|----------------|
| 12" | 48" | 447067 | 20 |
| | 60" | 447068 | 22 |
| | 72" | 447069 | 24 |

BACKSPLASHES

Powered Backsplashes include 15 or 20 Amp grounded receptacles, on/off switch with built-in circuit breaker, and a 10 ft. power cord. Backsplashes can be mounted between uprights or directly onto the worksurface.

Installation guide and mounting hardware included.

ESD Backsplashes feature dielectric insulation.

Non-Powered Backsplashes Worksurface Mounted Only

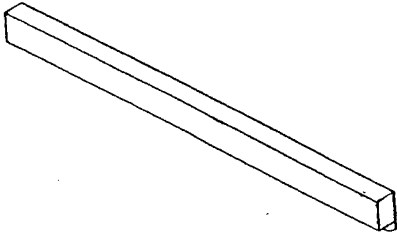

| Workstation Width | Standard | ESD | Approx. Weight |
|-------------------|----------|----------|----------------|
| 48" | 4048000 | 4048000E | 9 |
| 60" | 4060000 | 4060000E | 11 |
| 72" | 4072000 | 4072000E | 13 |

Powered Backsplashes Worksurface Mounted Only

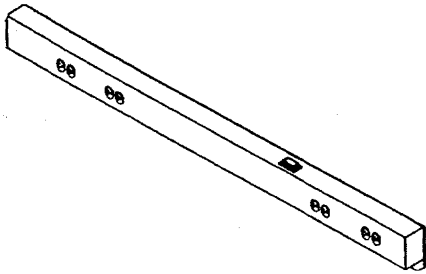

| Workstation Widths | | Outlets | 15 AMP | 20 AMP | Approx. Weight |
|--------------------|---|---------|---------|---------|----------------|
| 48" | 8 | | 4048158 | 4048208 | 10 |
| 60" | 8 | | 4060158 | 4060208 | 12 |
| 72" | 8 | | 4072158 | 4072208 | 14 |

ESD Backsplashes Worksurface Mounted Only

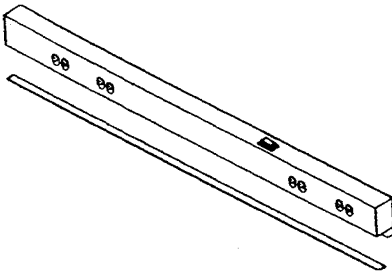

| Workstation Widths | | Outlets | 15 AMP | 20 AMP | Approx. Weight |
|--------------------|---|---------|----------|----------|----------------|
| 48" | 8 | | 4048158E | 4048208E | 10 |
| 60" | 8 | | 4060158E | 4060208E | 12 |
| 72" | 8 | | 4072158E | 4072208E | 14 |

Powered Backsplashes Upright Mounted Only

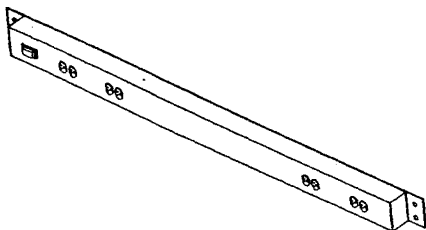

| Workstation Width | Outlets | 15 AMP | 20 AMP | Approx. Weight |
|-------------------|---------|--------|--------|----------------|
| 48" | 8 | 447094 | 447104 | 15 |
| 60" | 8 | 447095 | 447105 | 20 |
| 72" | 8 | 447096 | 447106 | 25 |

STORAGE

All hanging drawers and cabinets are made of steel and feature metal drawer fronts with recessed handle or bow pulls. Personal and Box drawers are suspended with two-member ball bearing slides, and the file drawers are suspended with three-member ball bearing slides.

Include (1) Mounting Bracket for each hanging drawer configuration attaching directly to worksurface.

* All dimensions are nominal

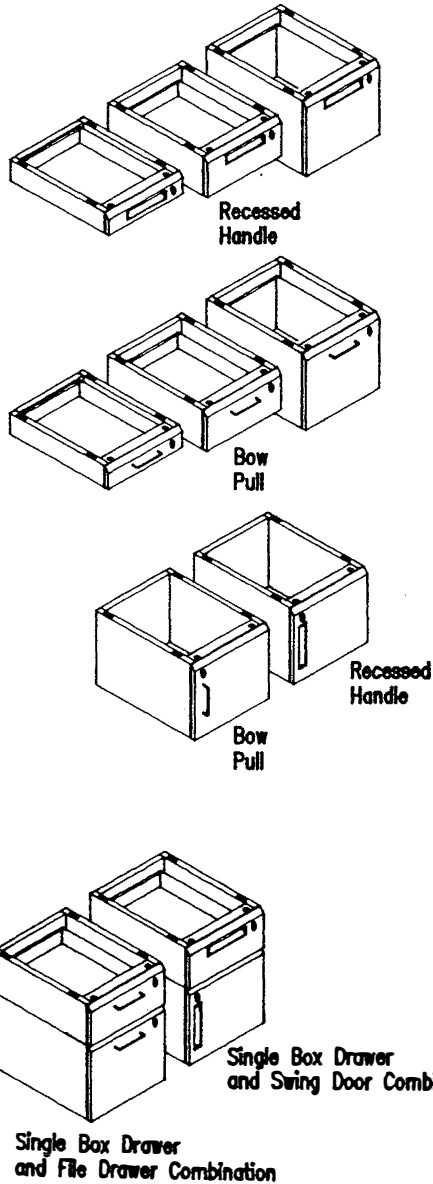

Lockable Hanging Drawers/Cabinets

| Description | Inside Dimensions | | |
|--------------------|-------------------|-------|--------|
| | Depth | Width | Height |
| Personal Drawer | 18" | 12½" | 1½" |
| Box Drawer | 18" | 12½" | 4½" |
| File Drawer | 18" | 12½" | 9½" |
| Left Door Cabinet | 19½" | 13" | 11¾" |
| Right Door Cabinet | 19½" | 13" | 11¾" |

| Description | Overall Height | Recessed Handle | Bow Pull | Approx. Weight |
|--------------------|----------------|-----------------|----------|----------------|
| Personal Drawer | 4" | 407400 | 407401 | 8 |
| Box Drawer | 7" | 407402 | 407403 | 16 |
| File Drawer | 14" | 407404 | 407405 | 32 |
| Left Door Cabinet | 14" | 407406 | 407407 | 19 |
| Right Door Cabinet | 14" | 407408 | 407409 | 19 |

| Description | Product Number | Approx. Weight |
|------------------|----------------|----------------|
| Mounting Bracket | 447051 | 8 |

Note:

Please specify keying and color instructions when ordering.
 Drawers can be keyed alike, differently, by workstation or by area.
 Drawer/Cabinet front colors: Sand Tan, Flint Gray, Fashion Blue, White and Black

MOBILE PEDESTALS

Mobile Pedestals are made of steel and include a built-in cylinder lock. The pedestals are counterbalanced to protect against tilting and feature casters with a friction brake to prevent inadvertent movement. A top is included with a built-in grip for ease of movement. Inside dimensions are: Personal Drawer 1 5/8"H, Box Drawer 4 1/2"H, File Drawer 9 1/2"H and Door 19 3/4"H. Pedestals are 24" in depth and available in 26" and 29" heights.

*All dimensions are nominal

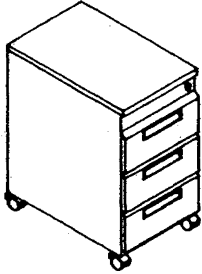

| Drawer/Door Configuration | Height | Recessed Handle | Bow Pull | Approx. Weight |
|---------------------------|--------|-----------------|----------|----------------|
| 3 Box | 26" | 447160 | 447170 | 90 |

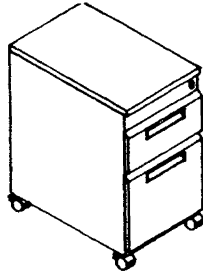

| Drawer/Door Configuration | Height | Recessed Handle | Bow Pull | Approx. Weight |
|---------------------------|--------|-----------------|----------|----------------|
| 1 Box, 1 File | 26" | 447161 | 447171 | 85 |

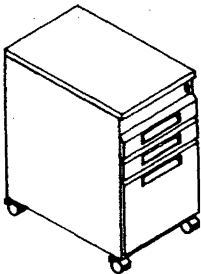

| Drawer/Door Configuration | Height | Recessed Handle | Bow Pull | Approx. Weight |
|---------------------------|--------|-----------------|----------|----------------|
| 2 Personal, 1 File | 26" | 447162 | 447172 | 90 |

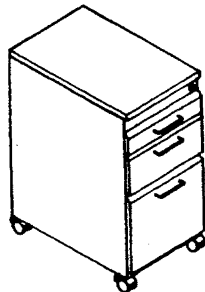

| Drawer/Door Configuration | Height | Recessed Handle | Bow Pull | Approx. Weight |
|---------------------------|--------|-----------------|----------|----------------|
| 1 Personal, 1 Box, 1 File | 29" | 447163 | 447173 | 98 |

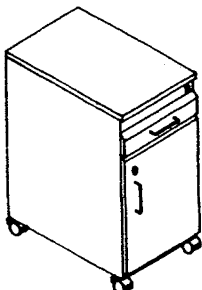

| Drawer/Door Configuration | Height | Recessed Handle | Bow Pull | Approx. Weight |
|---------------------------|--------|-----------------|----------|----------------|
| 1 Personal, 1 Door | 29" | 447164 | 447174 | 88 |

Note:

Please specify keying and color instructions when ordering.

Drawers can be keyed alike, differently, by workstation or by area.

Drawer/Cabinet front colors: Sand Tan, Flint Gray, Fashion Blue, White and Black

LIGHTING

Task Lights mount between the accessory uprights and include an energy saving ballast and on/off switch. Hand knob allows for easy installation to the light fixture bracket. Diffuser offers easy removal for fluorescent tube replacement. Fluorescent tubes, mounting brackets and mounting hardware are included.

Task Lights

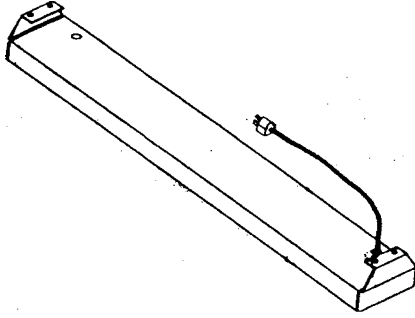

| Workstation Width | Product Number | Approx. Weight |
|-------------------|----------------|----------------|
| 48" | 447059 | 24 |
| 60" | 447060 | 26 |
| 72" | 447061 | 28 |

Magnifier Lights feature a 5", 3-diopter double convex precision ground lens which produces distortion-free magnification under bright fluorescent illumination. A 42" reach, steel arm with three-way adjustment is included. 6 ft. power cord provided. Available in black and almond.

Include (1) Magnifier Light bracket per Magnifier Light.

Magnifier Lights

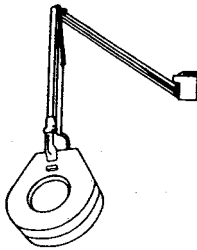

| Description | Product Number | Approx. Weight |
|--------------------------|----------------|----------------|
| Magnifier Light - Almond | 980030 | 9 |
| Magnifier Light - Black | 980194 | 9 |

| Description | Product Number | Approx. Weight |
|-------------------------|----------------|----------------|
| Magnifier Light Bracket | 447130 | 2 |

BIN BARS

Standard Bin Bars are painted steel. ESD Bin Bars are stainless steel with grounding kit included.

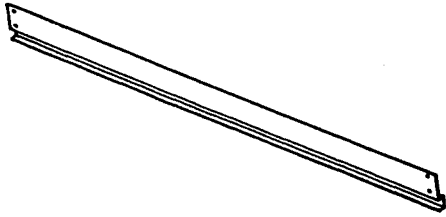

| Worksurface Width | Standard | ESD | Approx. Weight |
|-------------------|----------|--------|----------------|
| 48" | 447014 | 447017 | 3 |
| 60" | 447015 | 447018 | 4 |
| 72" | 447016 | 447019 | 5 |

PARTS BINS

Standard Parts Bins

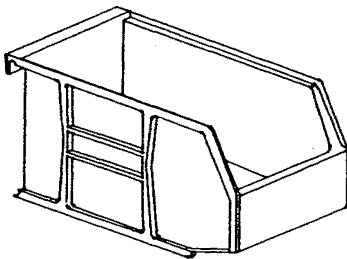

| Product* Number | Inside Dimensions | | | Carton Qty | Approx. Weight |
|-----------------|-------------------|--------|--------|------------|----------------|
| | L | W | H | | |
| ACC30210_ | 4 3/4" | 3 1/2" | 2 1/2" | 24 | 10 |
| ACC30220_ | 6 3/4" | 3 1/2" | 2 7/8" | 24 | 10 |
| ACC30230_ | 10 1/4" | 4 3/8" | 4 3/4" | 12 | 10 |
| ACC30240_ | 14" | 6 1/2" | 6 3/4" | 12 | 10 |

* Specify color preference with a suffix to the product number:
Only one color per carton may be ordered.

Standard Bin Colors: **Y** - Yellow, **B** - Blue and **R** - Red

ESD Parts Bins

| Product* Number | Inside Dimensions | | | Carton Qty | Approx. Weight |
|-----------------|-------------------|--------|--------|------------|----------------|
| | L | W | H | | |
| ACC4452 | 4" | 3 1/2" | 2 1/2" | 1 | 1 |
| ACC4453 | 6" | 3 3/8" | 2 1/2" | 1 | 1 |
| ACC4454 | 9" | 4 3/8" | 4 3/8" | 1 | 1 |

* ESD Bins are available in Black only.
All dimensions are nominal

TOOL BARS

Tool Bars are painted steel. Task Lights and Tool Bars may be mounted on one support kit.

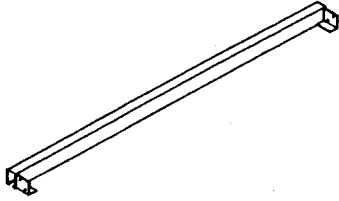

| Worksurface Width | Product Number | Approx. Weight |
|-------------------|----------------|----------------|
| 48" | 447034 | 4 |
| 60" | 447035 | 5 |
| 72" | 447036 | 6 |

Tool Bar Trolleys



Tool Bar Trolleys include an eye bolt to accept a variety of tool balancers.

| Description | Product Number | Approx. Weight |
|------------------|----------------|----------------|
| Tool Bar Trolley | 407115 | 1 |

FOOTRAILS

Footrails are painted steel and feature depth adjustment.

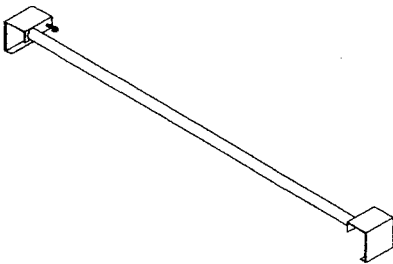

| Description | Product Number | Approx. Weight |
|---------------|----------------|----------------|
| 48"W Footrail | 447124 | 10 |
| 60"W Footrail | 447125 | 15 |
| 72"W Footrail | 447126 | 20 |

ACCESSORIES

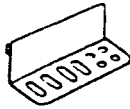

| Description | Product Number | Weight |
|-------------|----------------|--------|
| Tool Holder | 407260 | 1 |

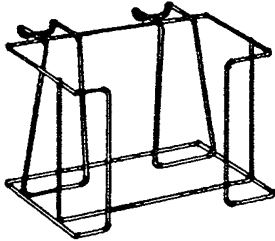

| Description | Product Number | Weight |
|----------------|----------------|--------|
| Kimwipe Holder | ACC7001 | 1 |

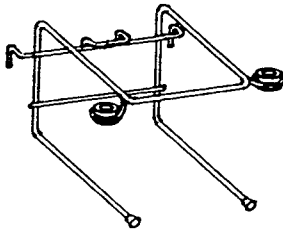

| Description | Product Number | Weight |
|-------------------|----------------|--------|
| Dual Solder Spool | ACC7002 | 1 |

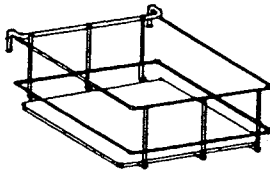

| Description | Product Number | Weight |
|---------------|----------------|--------|
| Bottle Holder | ACC7004 | 1 |

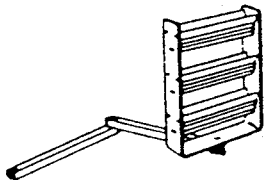

| Description | Product Number | Weight |
|-----------------------|----------------|--------|
| Articulating Bin Rack | 447131 | 11 |

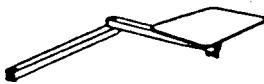

| Description | Product Number | Weight |
|-----------------------------|----------------|--------|
| Articulating Solder Station | 447132 | 8 |

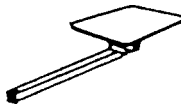

| Description | Product Number | Weight |
|-------------------------------|----------------|--------|
| Articulating Monitor Platform | 447133 | 10 |

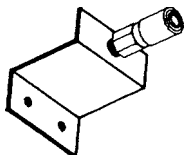

| Description | Product Number | Weight |
|----------------------|----------------|--------|
| Quick Air Disconnect | 447134 | 1 |

ESD OPTIONS

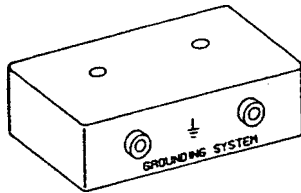

The Wrist Strap Grounding System provides grounding of two wrist straps using a common point to ground. It measures 3" X 1 1/2" and mounts easily on the bench. (2) built-in banana jacks and 10 ft. grounding cord are included.

| Description | Product Number | Weight |
|---------------------------|----------------|--------|
| Wrist Strap Grounding Kit | 990519 | 1 |

The wrist strap ensures all-around skin contact and electrical conductivity. 5 ft. coiled cord included.

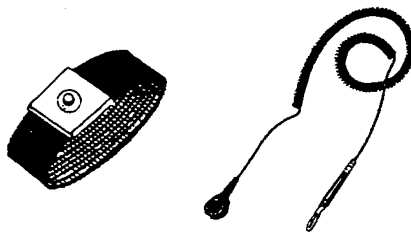

| Description | Product Number | Weight |
|-------------|----------------|--------|
| Wrist Strap | 990517 | 1 |

Accessory Grounding Kit can be used with Bin Bars and Shelves.

| Description | Product Number | Weight |
|-------------------------|----------------|--------|
| Accessory Grounding Kit | 407200 | 1 |

| Description | Product Number | Weight |
|----------------------------|----------------|--------|
| Drawer/CabinetGroundingKit | 407201 | 1 |

ESD Shelf Mats

ESD Shelf Mats are used when a static dissipative surface on a shelf is desired. All necessary grounding hardware included.

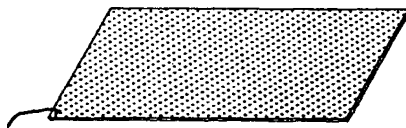

| Depth | Width | Standard* | Approx. Weight |
|-------|-------|-----------|----------------|
| 12" | 48" | 407206_E | 2 |
| | 60" | 407207_E | 2 |
| | 72" | 407208_E | 2 |

*Specify color preference with a suffix to the product number:

GENERAL ORDERING INFORMATION

Pricing, Terms, and Conditions

Net 30 days with established credit.

All prices are F.O.B. Factory and are subject to change without notice. Due to our continual research and development, changes may occur in product specifications. We reserve the right at any time to alter design and to substitute materials and parts to supply the article which is our standard at time of shipment.

Remit all payments to Custom Products & Services, Inc., 6286 Claude Way E, Inver Grove Heights, MN. 55076. No state or local sales tax, or any other tax that may be levied or assessed upon a sale or purchase of products listed in this ordering guide is included in prices quoted. Any such taxes must be paid by the purchaser, and if, by law, the vendor is chargeable with the collection or payment thereof, the sum must be added as tax to the prices quoted.

Order Confirmation

All orders are acknowledged upon receipt. It is the customer's responsibility to see that the items shown conform to those ordered, and if any discrepancy exists, to notify Custom Products & Services, Inc immediately. The order acknowledgement is the final agreement between the customer and CPS and supersedes all prior documents and may not be modified except by a revised purchase order.

Shipping

All shipments are made "best way" (motor freight, common carrier, UPS) unless otherwise requested in writing. CPS is not responsible for delay in shipment caused by conditions beyond our control. All weights shown are approximate and obtained from standard packaging procedures.

Damage in Transit

Customer should inspect shipment upon receipt. All loss or damage claims must be made against the carrier. No claims for damage may be deducted from invoices.

Returns

Contact Custom Products & Services for RMA. Restocking charges up to 20% may apply

Colors

Standard paint colors for Sturdilite Technical Workstations are Sand Tan, Dove Gray, Flint Gray, Metallic Gray, Ice Blue, Fashion Blue, Navy, Burgundy, Mocha, Black and White. Customized colors are available upon request.

Assembly

Some assembly is required. Instruction manuals will accompany all orders.

Specifications

A complete set of product specifications is available upon request. All dimension listed are nominal.

Special Product Requests

If quantities or circumstances warrant, we will be pleased to quote pricing on custom products.

How to Order

Contact Custom Products & Services, Inc. PH: 888-444-1202 or 651-452-0113

Email: sales@custom-products.com